

This document must not be copied without our written permission, and the contents thereof must not be imparted to a third party nor be used for any unauthorized purpose. Contravention will be prosecuted.

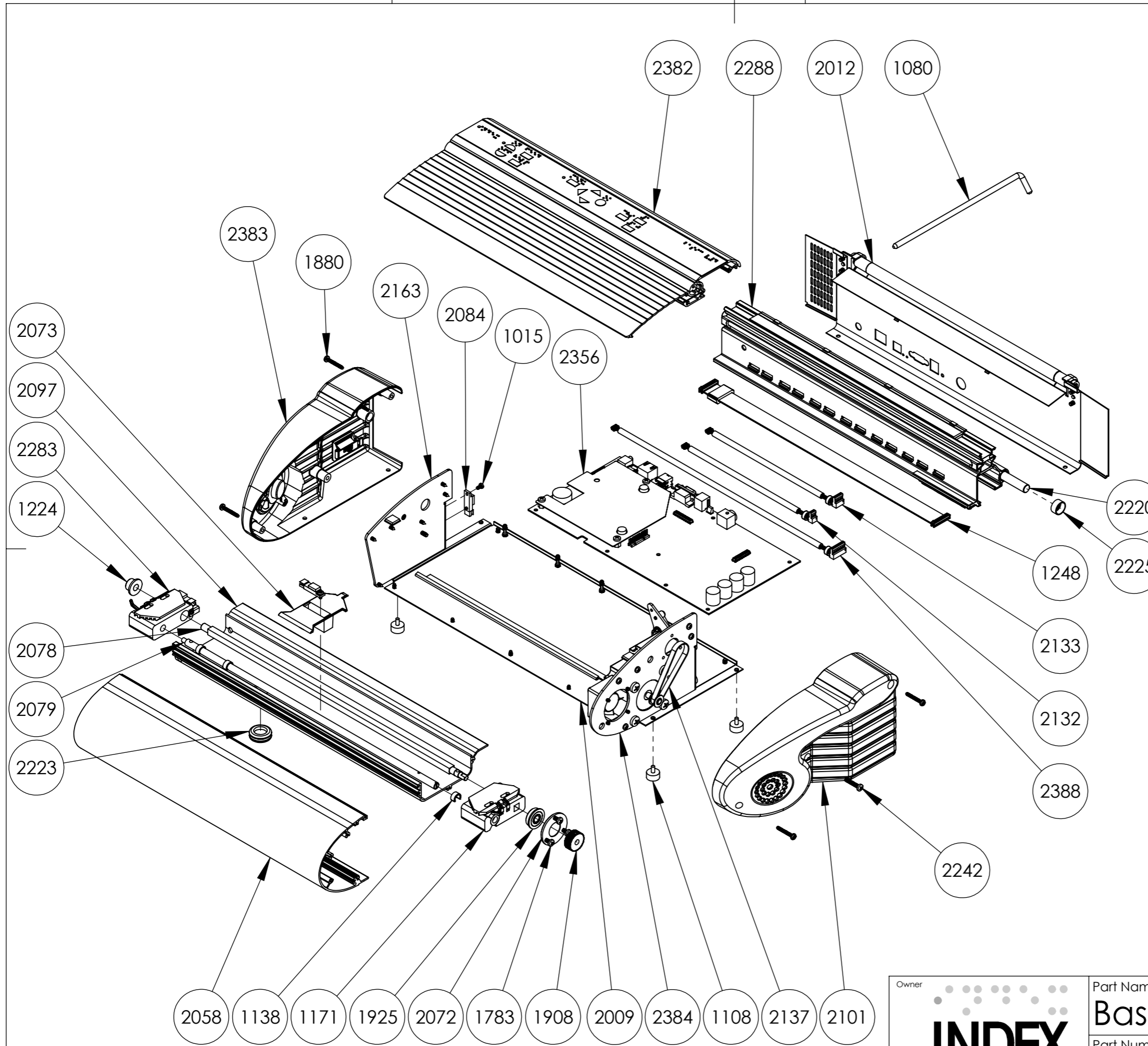

2	Feet Small Square Black	2258
4	Screw RXK ST3,5x25 fzb	1880
2	Screw MRX M4x8 fzb	2230
4	Lock Washer AZ4,3 fzb	1008
6	Screw RXK ST3,5x6,5 fzb black	1028
2	Screw MRX M4x22 fzb	2242
1	Screw MRX M3x6 fzb black	1015
3	Screw MRX M4x6 fzb	1783
12	Screw RXS 3,5x9,5-fzb	1293
1	Cable Embosser Head Sensor	2388
1	Cable Embosser Head	1248
1	Paper Jam Sensor Cable	2133
1	Paper Sensor Cable	2132
1	Transport Locking	1080
3	Position clips	1138
1	Cable Grommet	2223
1	Embosser Head Basic	2288
1	Locking Ring	2225
1	Axle 10x488	2220
4	Feet rubber with screw M4	1108
2	Paper Sensor	2084
1	Tractor Left Sensor Side	2283
1	Tractor Right	1171
1	Plate Back Basic V4 Module	2012
1	Module Main Board PCB V4	2356
1	Arrow Paper Sensor	2073
1	Timing Belt	2137
1	Pulley 36 step	1908
1	Ball Bearing Cover	2072
1	Ballbearing F608-ZZ	1925
1	Axle 8x8 mm square	2078
1	Axle 8mm	2079
1	Holder bearing gliding tractor	1224
1	Casing Left Speaker Module	2383
1	Casing Right Fan	2101
1	Profile Panel Module	2382
1	Profile Tractor	2097
1	Profile front	2058
1	Plate left	2163
1	Plate Right Motor Module	2384
1	Plate Bottom	2009
QTY	Part Name	Part Number



Owner	Part Name			
	Basic-D V4			
	Part Number	Drawn by	Approved by	Format
	2000	Mattias		A3
		Date	Revision	Scale
		2012-06-21		1:20
			Sheet	
			1/1	

This document must not be copied without our written permission, and the contents thereof must not be imparted to a third party nor be used for any unauthorized purpose. Contravention will be prosecuted.

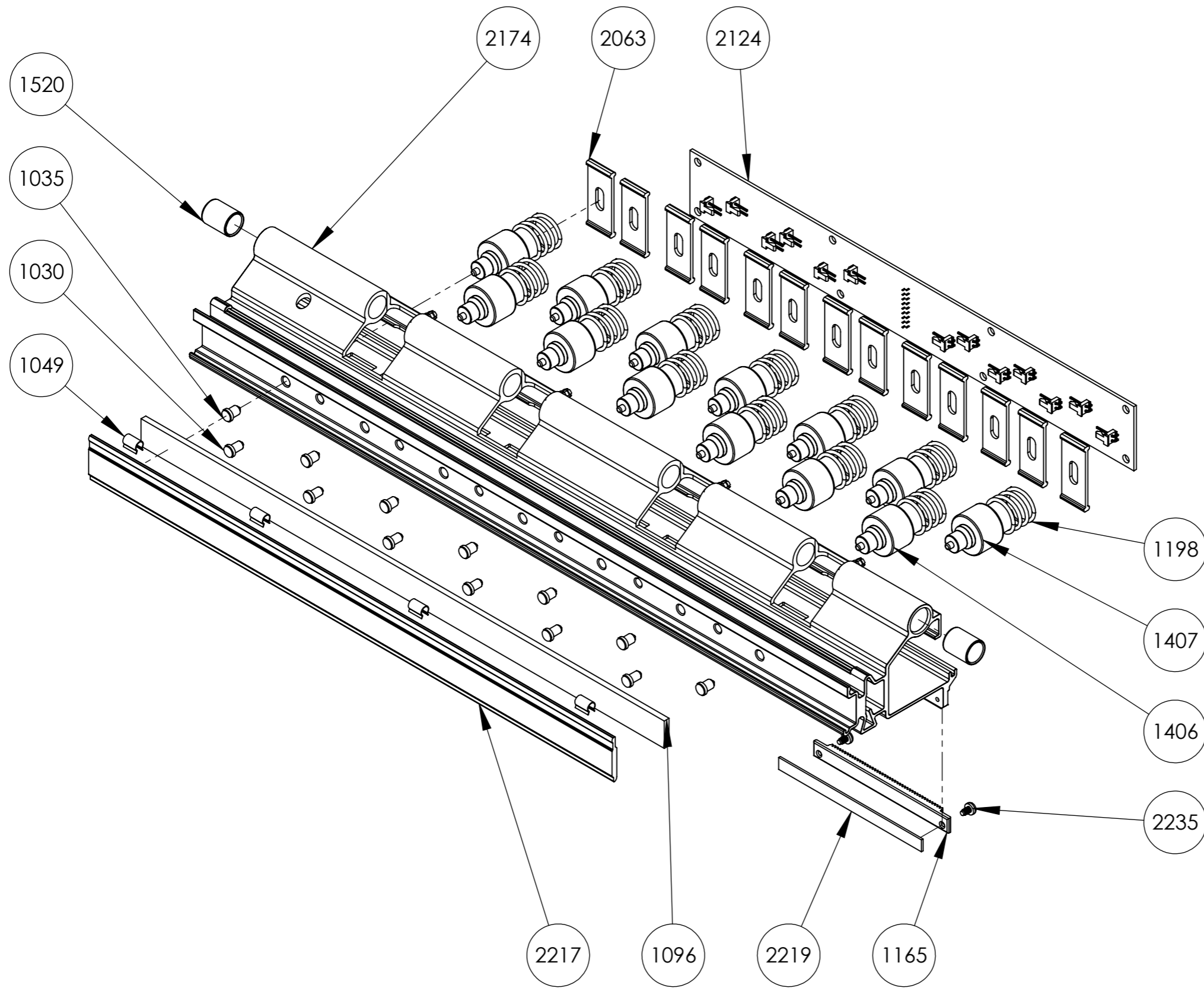

2	Screw RXK ST2,9x4,5 fzb	2235
7	Hammer Negative	1407
6	Hammer Positive	1406
1	Bord Embossing Head PCB V4	2124
1	Embosser Head Plastic	2219
1	Gear bar, embosser head	1165
13	Profile Hammer Lid	2063
13	Spring for hammer	1198
4	Holder clips Embosser Head	1049
1	Rubber damper	1096
1	Profile Anvil	2217
6	Anvil Negative	1030
7	Anvil Positive	1035
2	Slide Bearing	1520
1	Profile Hammer Basic	2174
QTY	Part Name	Part Number



Owner		Part Name			
		Embosser Head Basic			
Part Number		Drawn by	Approved by	Format	Scale
2288		Mattias		A3	1:5
Date		Revision	Sheet		
2012-06-19			1/1		

This document must not be copied without our written permission, and the contents thereof must not be imparted to a third party nor be used for any unauthorized purpose. Contravention will be prosecuted.

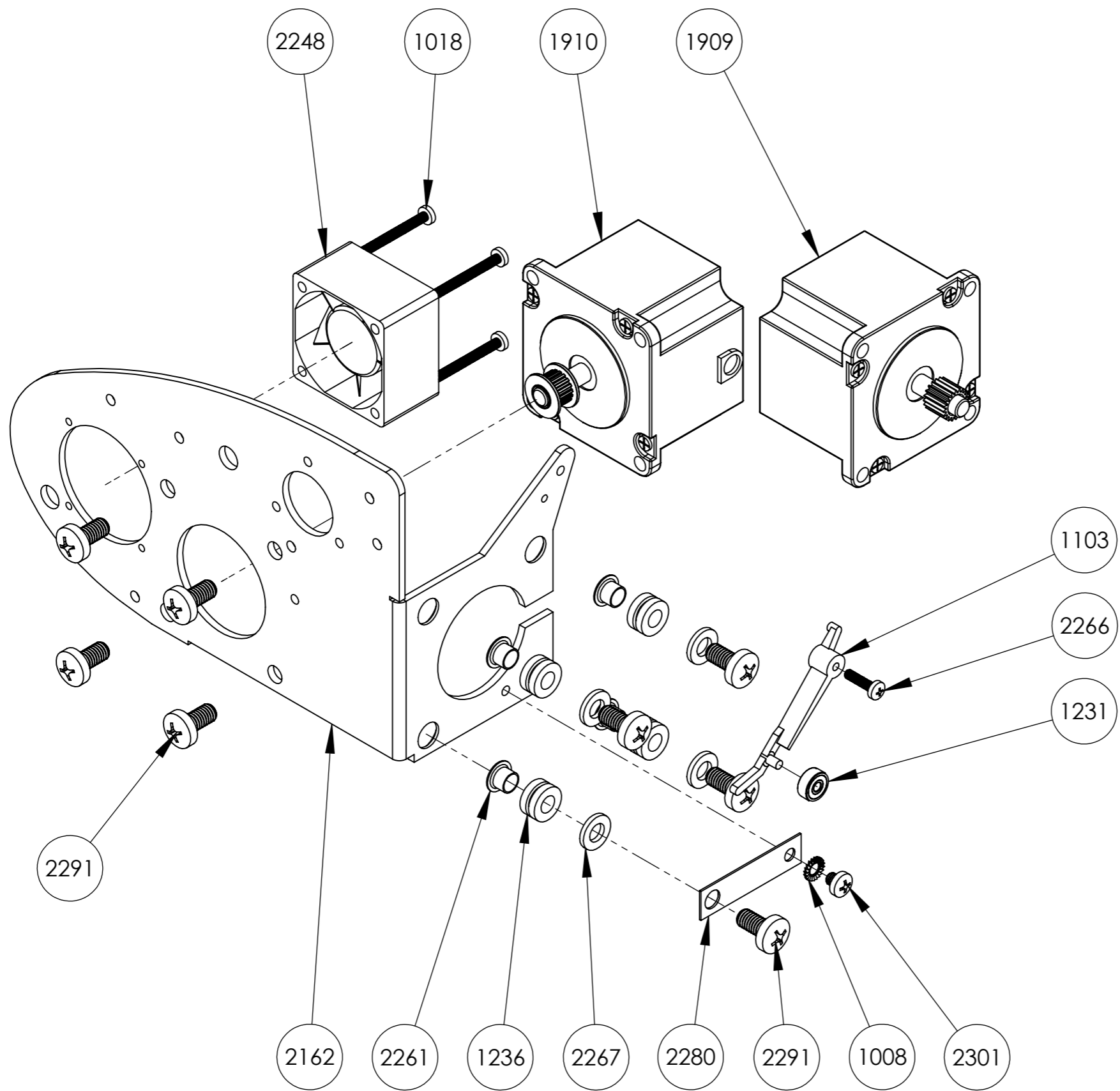

1	Screw MRX M3x12 fzb	2266
1	Screw MRX M4x4 fzb	2301
4	Screw MRX M3x30 fzb	1018
8	Screw MRX M6x12 fzb	2291
1	Lock Washer AZ4,3 fzb	1008
4	Washer BRB HB200 6,4x12x1,6 fzb	2267
1	BallBearing 623-ZZ	1231
1	Grounding Plate Motor	2280
1	Spring Stretcher	1103
1	Stepper Motor Head	1909
1	Stepper Motor Paper	1910
4	Rubber damper	1236
4	Flange Pipe 7x0,45x5 P H10	2261
1	Fan 40x40x24	2248
1	Plate Right Motor	2162
QTY	Part Name	Part Number



Owner		Part Name	
INDEX BRAILLE		Plate Right Motor Module	
		Part Number	2384
Drawn by	Approved by	Format	Scale
Mattias		A3	1:5
Date	Revision	Sheet	
2012-06-20		1/1	

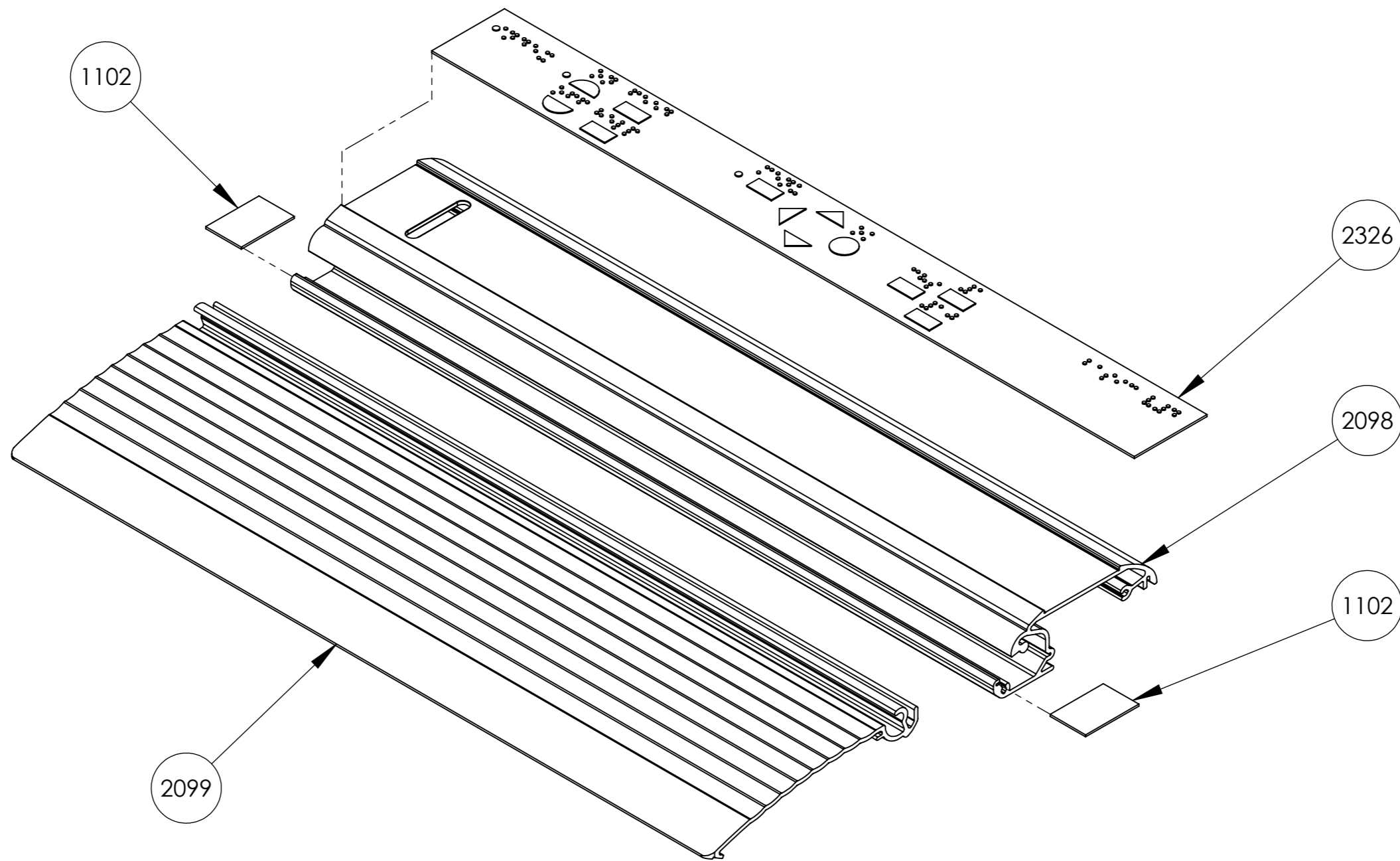

2	Spring led red	1102
1	Control Panel Basic V4	2326
1	Lid Black	2099
1	Profile Panel	2098
QTY	Part Name	Part Number

	Part Name Profile Panel Module			
	Part Number 2382	Drawn by Mattias	Approved by	Format A3
	Date		Revision	Scale 1:1
				Sheet 1/1

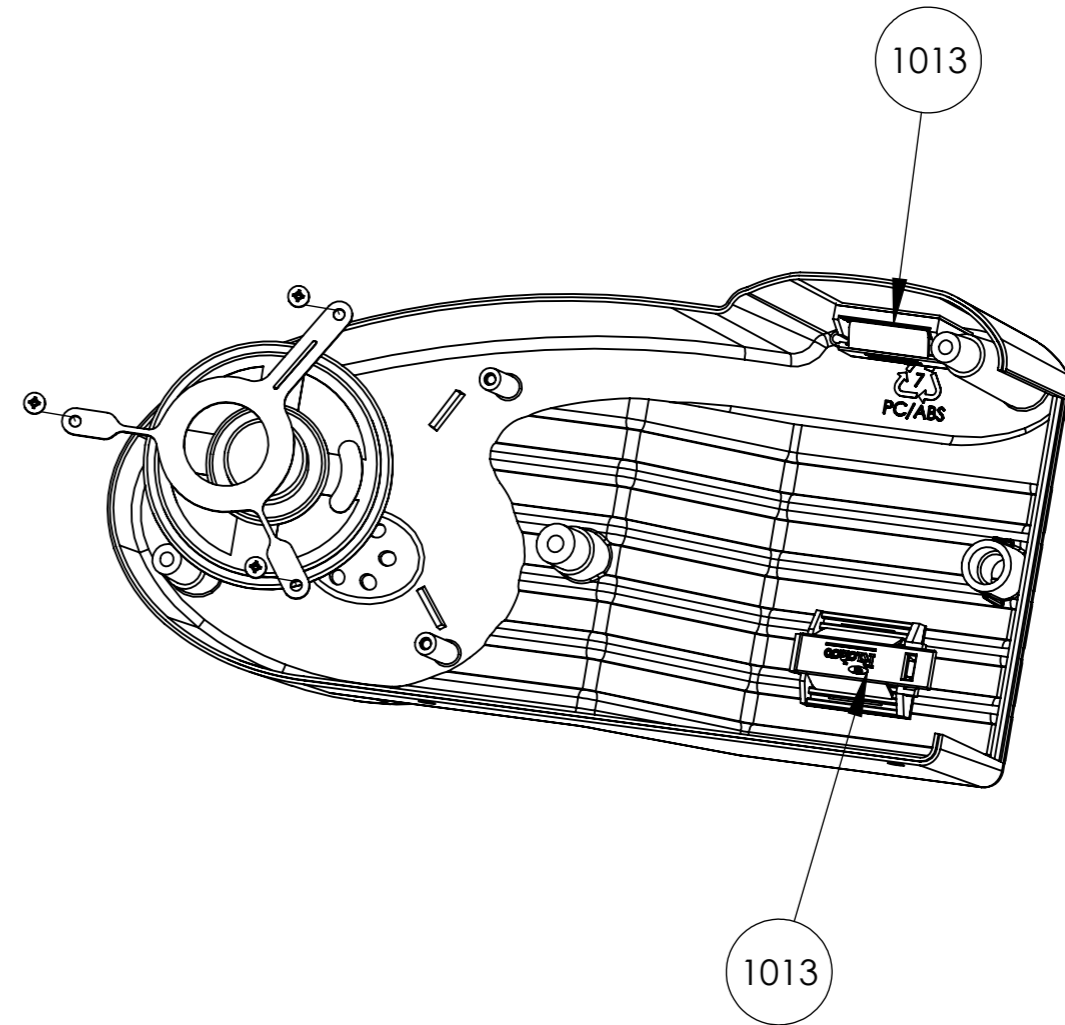
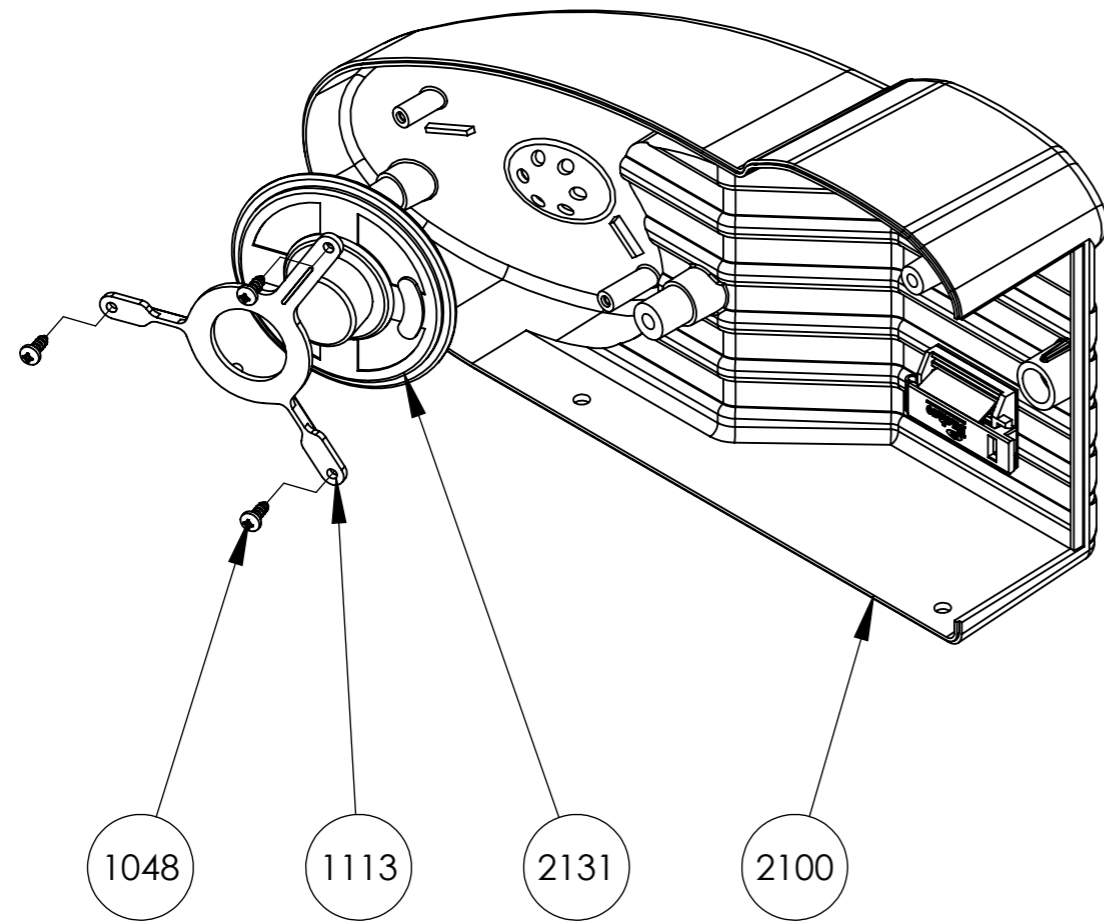

3	Screw PT-WN 1442 ST3,0x8 fzb	1048
2	Holder Cable	1013
1	Speaker Holder	1113
1	Speaker with Cable	2131
1	Casing Left Speaker	2100
QTY	Part Name	Part Number



Owner		Part Name	
		Casing Left Speaker Module	
Part Number		Drawn by	Approved by
2383		Mattias	
Date		Format	Scale
2012-06-19		A3	1:2
		Revision	Sheet
			1/1

This document must not be copied without our written permission, and the contents thereof must not be imparted to a third party nor be used for any unauthorized purpose. Contravention will be prosecuted.

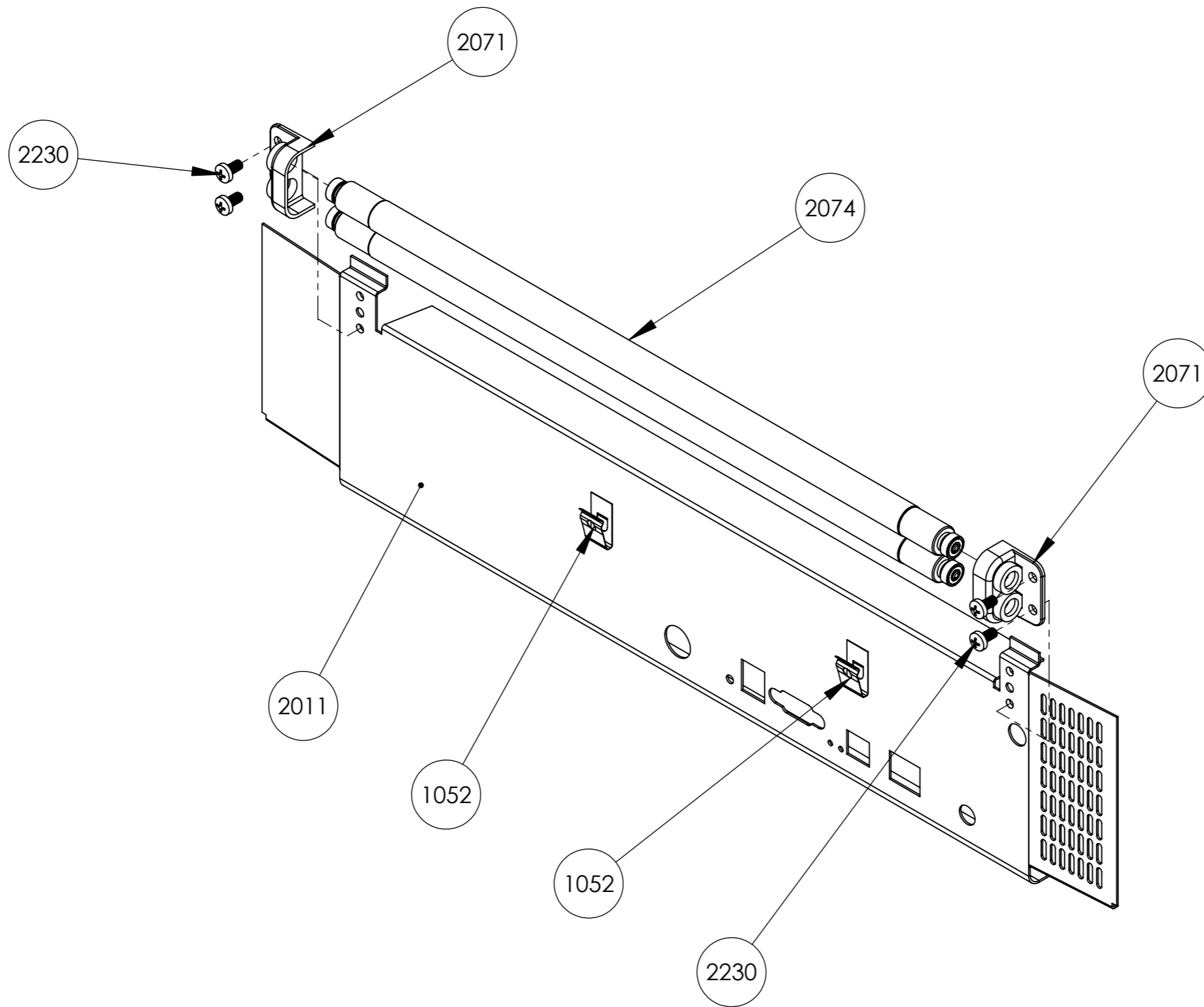

4	Screw MRX M4x8 fzb	2230
2	Holder Cips Transportlocking	1052
2	Shaft with Rubber	2074
2	Roller Attachment Back Plate	2071
1	Plate back	2011
QTY	Part Name	Part Number



Owner		Part Name	
INDEX BRAILLE		Plate Back Basic V4 Module	
		Part Number	2012
Drawn by	Approved by	Format	Scale
Mattias		A3	1:1
Date		Revision	Sheet
			1/1

This document must not be copied without our written permission, and the contents thereof must not be imparted to a third party nor be used for any unauthorized purpose. Contravention will be prosecuted.

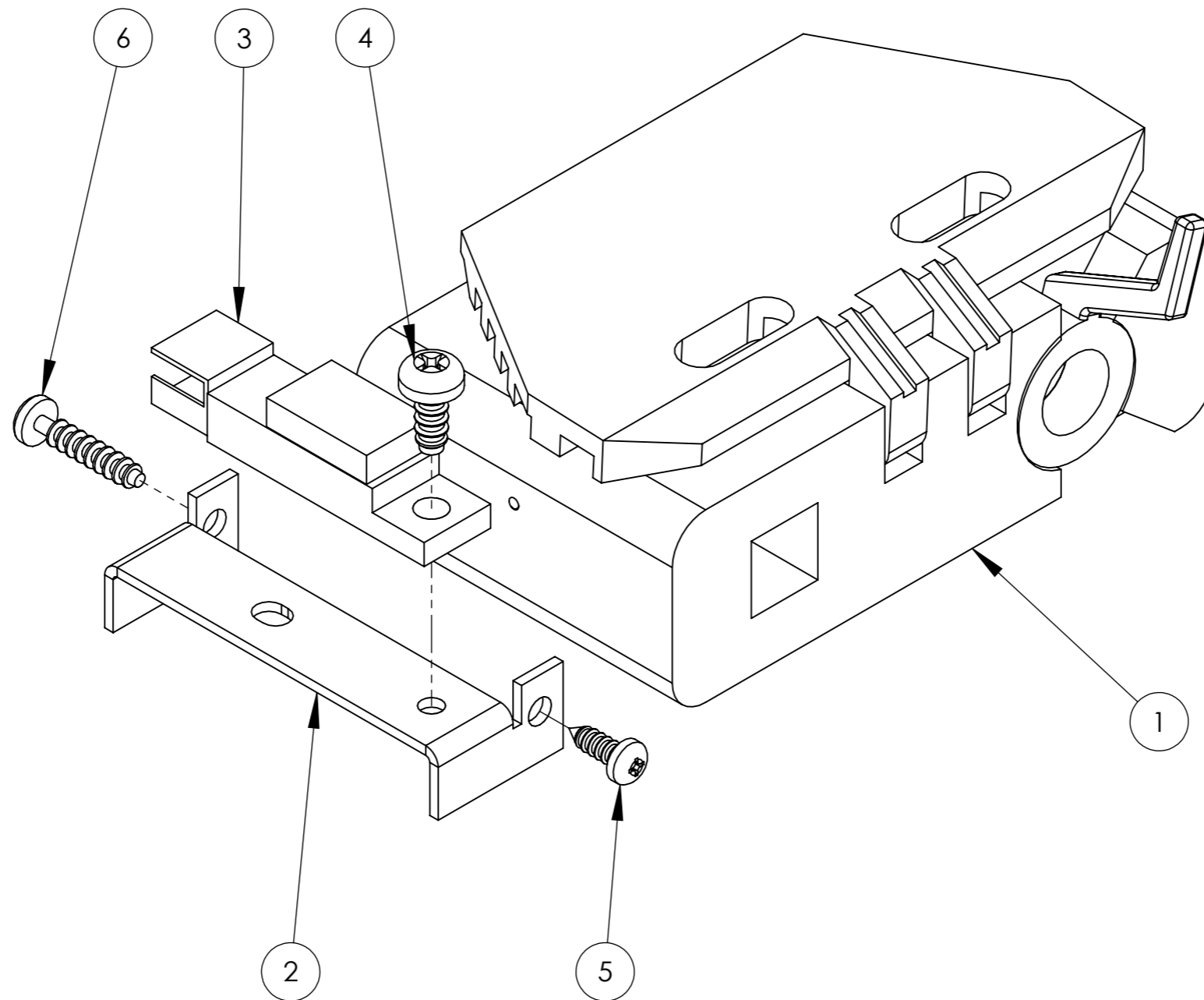

1	Screw WN 1412 2,5x12 fzb	2292
1	Screw RXS ST2,2x6,5 fzb	1045
1	Screw RXK ST2,9x6,5-fzb	1041
1	Paper Sensor	2084
1	Bracket Papersensor	2262
1	Tractor Left Switch Side	1173
QTY	Part Name	Part Number



Owner		Part Name	
		Tractor Left Sensor Side	
Part Number		Drawn by	Approved by
2283		Mattias	
Date		Format	Scale
2012-06-21		A3	1:1
		Revision	Sheet
			1/1