

This document must not be copied without our written permission, and the contents thereof must not be imparted to a third party nor be used for any unauthorized purpose. Contravention will be prosecuted.

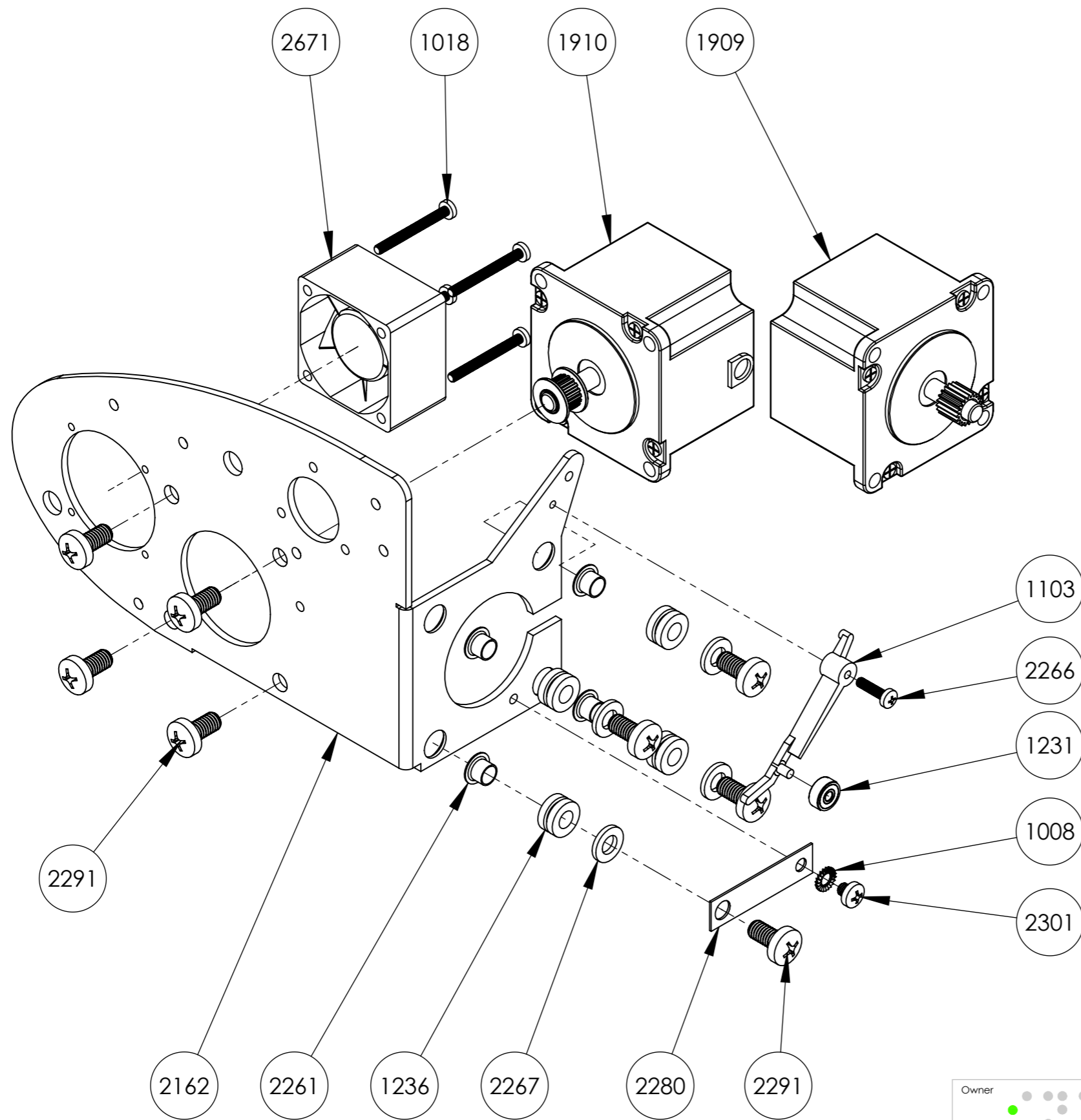

2671	Fan 40x40x24	1
2301	Screw MRX M4x4 fzb	1
2291	Screw MRX M6x12 fzb	8
2280	Grounding Plate Motor	1
2267	Washer BRB HB200 6,4x12x1,6 fzb	4
2266	Screw MRX M3x12 fzb	1
2261	Flange Pipe 7x0,45x5 P H10	4
2162	Plate Right Motor	1
1910	Stepper Motor Paper	1
1909	Stepper Motor Head	1
1236	Rubber damper	4
1231	BallBearing 623-ZZ	1
1103	Spring Stretcher	1
1018	Screw MRX M3x30 fzb	4
1008	Lock Washer AZ4,3 fzb	1
Part Number	Part Name	QTY



Owner		Part Name		
		<b>Plate Right Motor Module</b>		
Part Number		Drawn by	Approved by	Format
<b>2384</b>		Mattias	Janne	A3
Date		Revision		Scale
2016-09-06		-		1:5
		Sheet		1/1

This document must not be copied without our written permission, and the contents thereof must not be imparted to a third party nor be used for any unauthorized purpose. Contravention will be prosecuted.

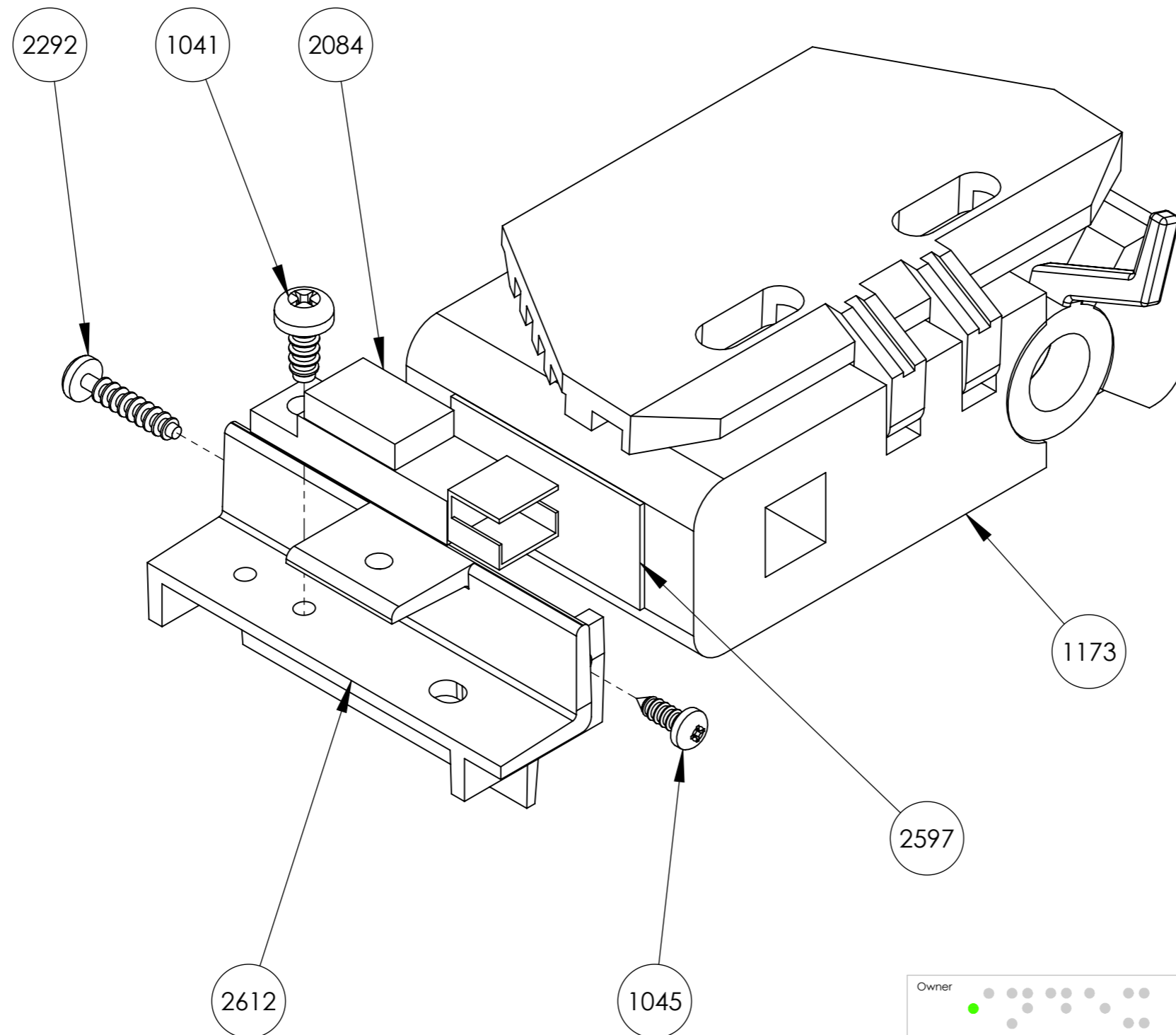

2597	Tape Attachment Pad	1
2292	Screw WN 1412 2,5x12 fzb	1
2612	Bracket Papersensor	1
2084	Paper Sensor	1
1173	Tractor Left Switch Side	1
1045	Screw RXS ST2,2x6,5 fzb	1
1041	Screw RXK ST2,9x6,5-fzb	1
Part Number	Part Name	QTY



Owner  
 Part Name  
**Tractor Left Sensor Side**

Part Number  
**2283**

Drawn by  
**Mattias**  
 Date  
 2016-09-06

Approved by  
**Janne**



Format  
**A3**

Revision  
 -

Scale  
 1:1

Sheet  
 1/1

This document must not be copied without our written permission, and the contents thereof must not be imparted to a third party nor be used for any unauthorized purpose. Contravention will be prosecuted.

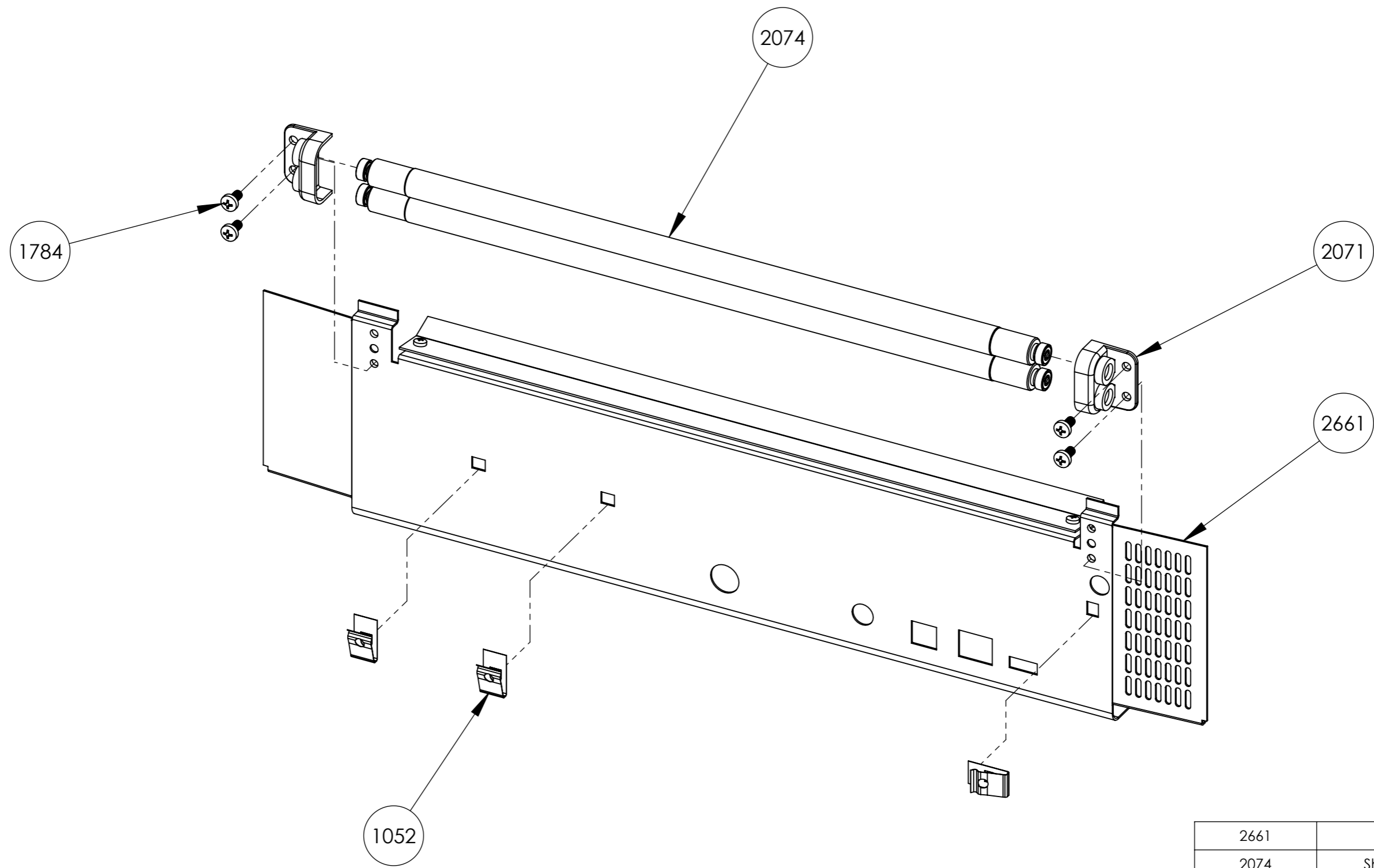

2661	Back Plate V5	1
2074	Shaft with Rubber	2
2071	Roller Attachment Back Plate	2
1784	Screw MRX M4x8 fzb	4
1052	Holder Cips Transportlocking	3
Part Number	Part Name	QTY

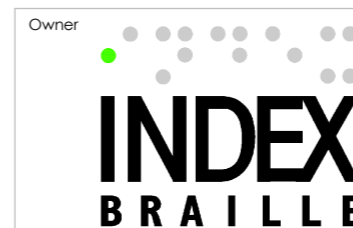

Owner	Part Name								
	<b>Plate Back Basic V5 Module</b>								
Part Number	2683	Drawn by	Mattias	Approved by	Janne	Format	A3	Scale	1:1
Date	2016-09-06	Revision	-	Sheet	1/1				

1102

2613

1102

2099

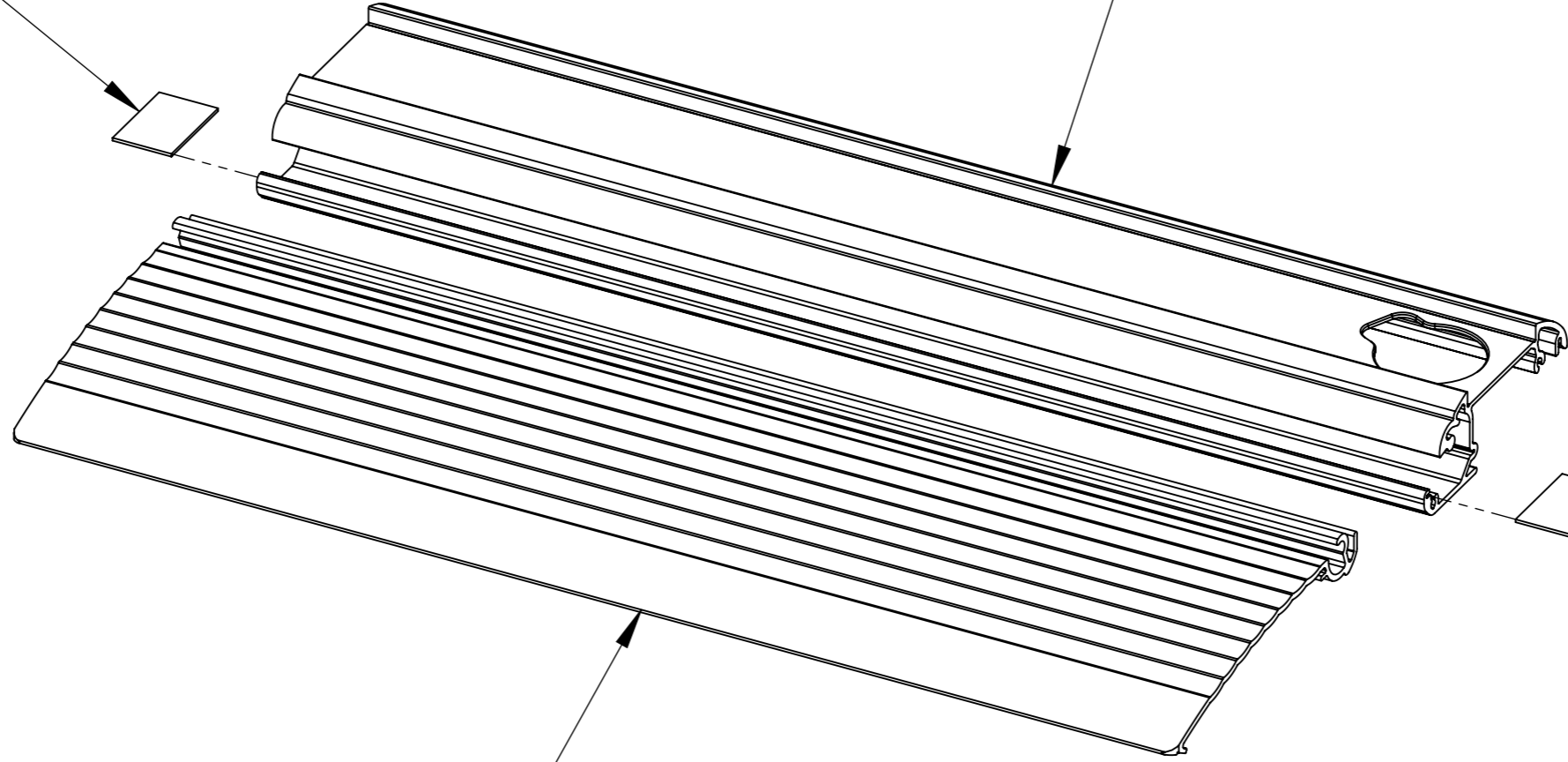

2613	Profile Panel	1
2099	Lid Black	1
1102	Spring led red	2
Part Number	Part Name	QTY

This document must not be copied without our written permission, and the contents thereof must not be imparted to a third party nor be used for any unauthorized purpose. Contravention will be prosecuted.



Owner		Part Name		Scale					
<b>INDEX BRAILLE</b>		Panel Profile Module		1:1					
		Part Number	2684	Drawn by	Mattias	Approved by	Janne	Format	A3
Date	2016-09-06	Revision	-	Sheet	1/1				

This document must not be copied without our written permission, and the contents thereof must not be imparted to a third party nor be used for any unauthorized purpose. Contravention will be prosecuted.

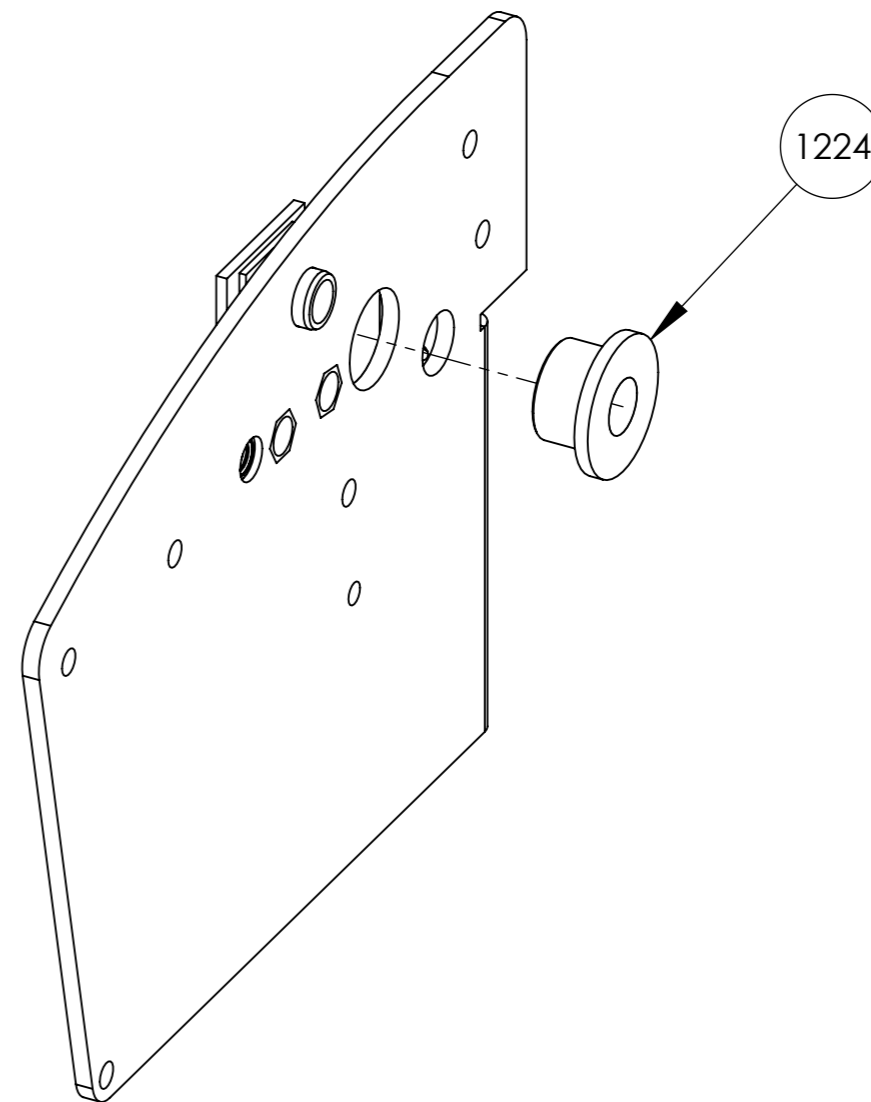
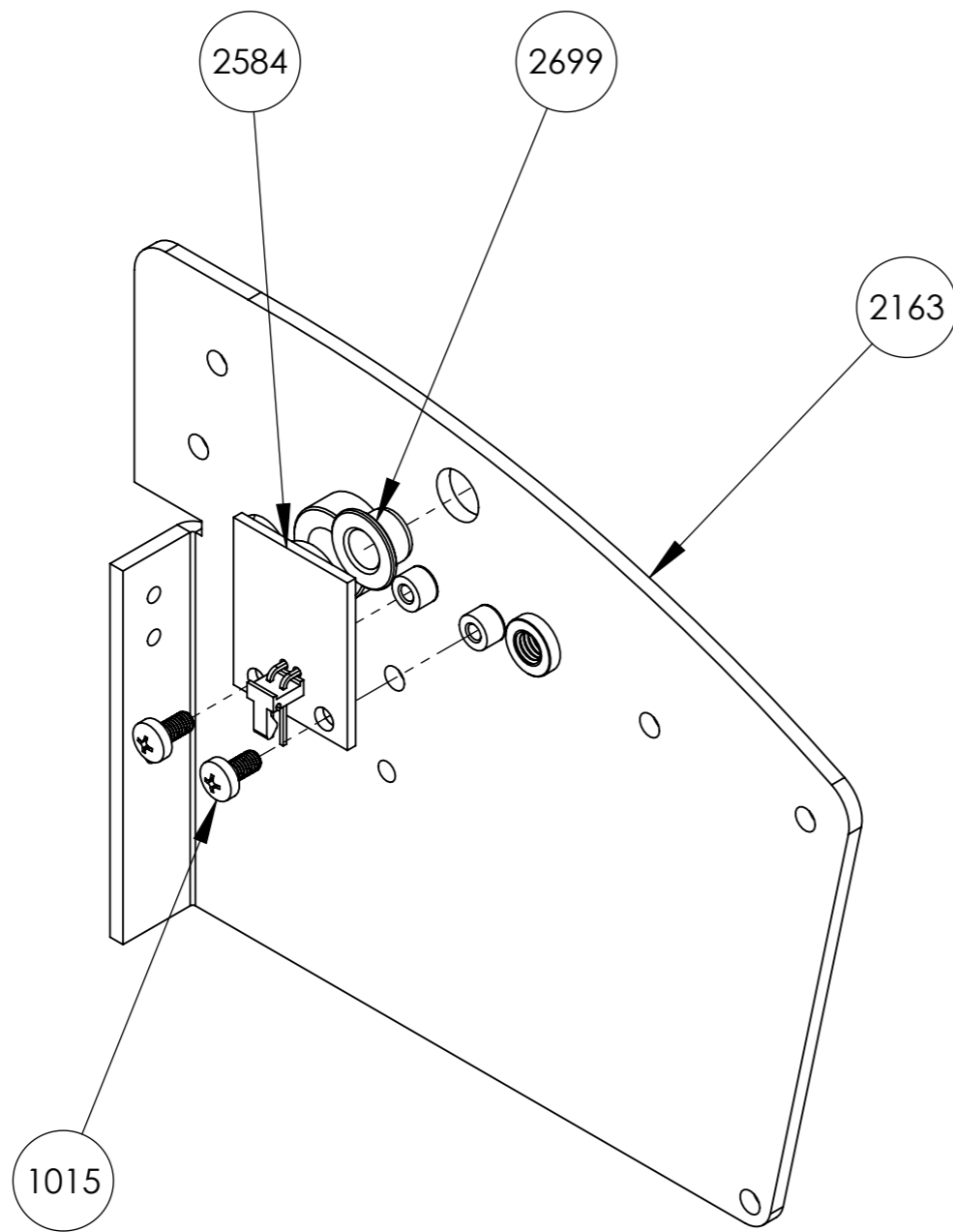

2699	Sliding Bearing 6x8x12 D=6	1
2584	Braille Box Lamp PCB V5	1
2163	Plate left	1
1224	Holder bearing gliding tractor	1
1015	Screw MRX M3x6 fzb black	2
Part Number	Part Name	QTY



Owner  
Part Name  
**Plate Left Module**

Part Number  
**2700**

Drawn by  
**Mattias**  
Date  
**2016-09-06**

Approved by  
**Janne**

Format  
**A3**  
Scale  
**1:1**  
Revision  
**-**  
Sheet  
**1/1**